

## T24-RA

Potentiometer Acquisition Module

User Manual

[www.mantracourt.co.uk](http://www.mantracourt.co.uk)

**ME** mantracourt

Wireless Telemetry Range 2.4Ghz

<b>Introduction / Overview</b> .....	<b>2</b>
<b>Connections</b> .....	<b>2</b>
Power .....	2
Input Connections .....	2
<b>Configuration</b> .....	<b>3</b>
Installation .....	3
T24 Toolkit.....	3
T24-BSu Base Station .....	3
T24 Toolkit .....	4
General Pages .....	4
Setup Base Station Communications .....	4
Home .....	5
Analyser .....	6
Data Provider Monitor .....	7
Information .....	8
Battery and Radio Levels .....	9
Battery and Radio Levels Advanced Settings.....	10
Data Rates and Quality.....	11
Input / Output Configuration .....	13
Calibration By Certificate.....	15
Calibration Advanced.....	16
Channel and Encryption.....	18
Save and Restore.....	19
Advanced Settings .....	20
<b>Installation</b> .....	<b>21</b>
Overview .....	21
Power Supply / Battery.....	22
Considerations When Selecting Batteries.....	22
Battery Types.....	23
Power Supply Modules.....	23
Lithium Ion /Polymer Module T24-BC1 .....	23
Physical Connections.....	24
Specification .....	24
Suitable Batteries .....	24
Capacitor Module T24-BC2 .....	25
Mounting .....	26
Antenna .....	27
Internal Chip Antenna .....	27
External Antennas .....	28
Antenna Orientation.....	28
<b>Specifications</b> .....	<b>29</b>
General Radio .....	29
T24-RA .....	29
<b>Approvals</b> .....	<b>30</b>
CE.....	30
FCC .....	30
Industry Canada.....	31
<b>OEM / Reseller Marking and Documentation Requirements</b> .....	<b>31</b>
FCC .....	31
IC.....	31
CE.....	31
<b>Declaration Of Conformity</b> .....	<b>33</b>
<b>Worldwide Regional Approvals</b> .....	<b>34</b>
Important Note.....	34
<b>Warranty</b> .....	<b>34</b>

## Introduction / Overview

The T24-RA is a remote acquisition module for the collection and processing of potentiometer resistance measurements. The module measures the resistance and periodically transmits it. Between transmissions the device is optionally in a power saving sleep mode to conserve batteries

Various devices are available that utilise the transmitted data and include handheld and PC displays etc.

## Connections

This section will show you how to get the device pair working out of the box. You will require a 3 Volt dc supply for the acquisition module which may be 2 X AA alkaline batteries.

### Power

Attach power supply wiring to the module as shown below:

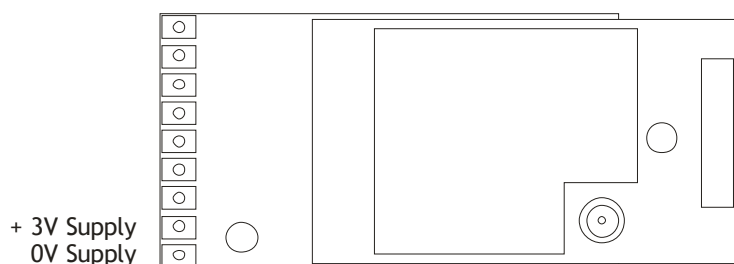

Connect to a 3 Volt power supply or batteries.

---

**WARNING: This module is not reverse polarity protected!**

**WARNING: The maximum voltage is 3.6V!**

---

### Input Connections

**NOTE: The acquisition module may already be mounted in a connectivity module. In this case please refer to the connectivity module user manual for the connection details.**

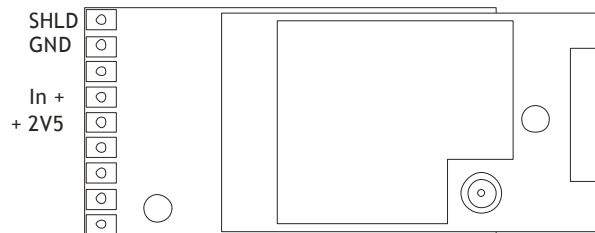

Basic configuration with potentiometer shown below:

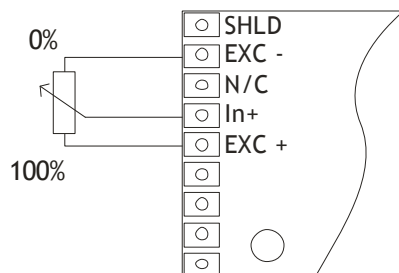

## **Configuration**

This section explains how to install software and configure the module. Please note that you will need the T24 Toolkit software and a T24-BS base station to allow your computer to communicate with T24 telemetry devices.

## **Installation**

### **T24 Toolkit**

To configure the devices we must use the **T24 Toolkit** software application. This can be downloaded from our web site or may be shipped with your products.

Install this on a PC or laptop.

Run setup.exe and follow the prompts to install the software.

### **T24-BSu Base Station**

If you have a USB version of the base station (T24-BSu) then you just need to plug this into a USB socket on your PC. If you are using an alternative base station then please refer to the appropriate manual.

## T24 Toolkit

The T24 Toolkit provides a means of simple configuration and calibration of the acquisition module along with useful tools to aid integration.

Run the T24 Toolkit software application.

PLEASE NOTE: Depending on which acquisition module is selected the screenshots may vary slightly. This will generally be in naming of units and device descriptions. The screenshots shown are those shown when a T24-PA strain gauge acquisition module is connected.

### General Pages

#### Setup Base Station Communications

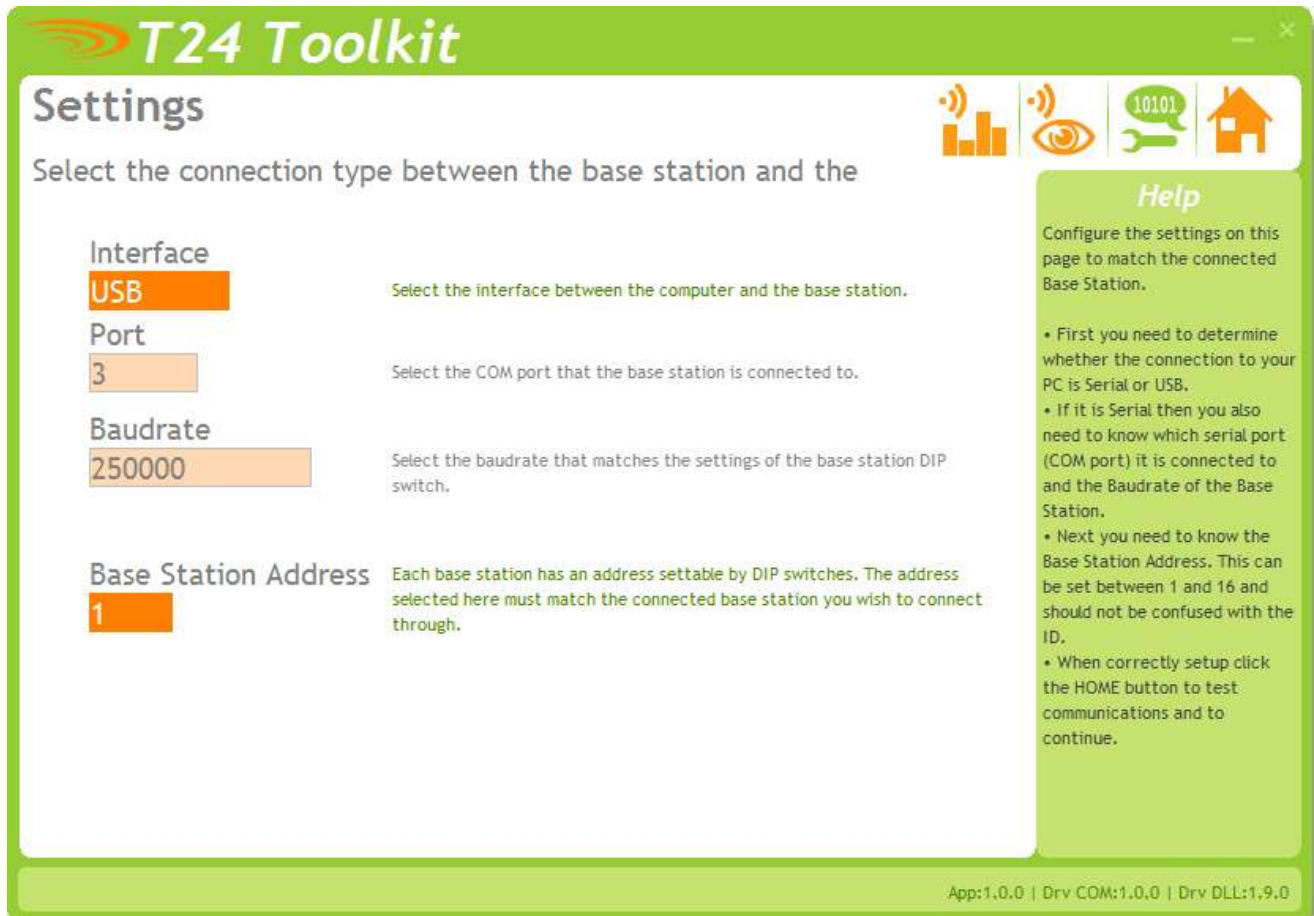

Select **USB** as the interface and select **1** as the Base Station Address.

In the toolkit all items that can be changed by the user are coloured orange.

To change a value just click on the relevant orange item. You will then be presented with a new dialog window allowing you to change the value.

This may use a slider, text box or list to allow your new value to be entered.

Click the Home button to attempt communications with the base station.

If no communications can be established the toolkit will remain on this page. You will need to check that the base station is powered and that it is connected to the converter correctly.

**Home**

**Monitor or Log**  
You can view and log the data being transmitted from an acquisition module or view the spectrum analyser by clicking the icons above right. Pairing is NOT required to log data from your device.

**Configure your device**  
To configure your module we need to temporarily pair to it. When we pair from the Toolkit we configure the base station radio settings to match the remote module.  
To pair you must:

- Remove the power from your module.
- Initiate the pair by clicking the button below.
- Re-apply the power to the module.

When applying power be careful to do this cleanly because if the module is powered up with an intermittent connection it may reset during pairing and result in poor or no communications.

**Pair**

If the module cannot be paired because access to the power supply is either not possible or many modules share the same power supply. [Click Here](#) for advanced connection options.

**Help**  
This Home page is where you begin your connection to your device.  
You must be able to access its power supply so you can remove and reapply it.  
The device you want to connect to must be the only device you reapply power to.  
When pairing to a device the base station settings are changed to match those of the remote device.  
[To connect to the base station hold the Shift key while clicking the Pair button]

Connected to Base Station of ID FFC8FF on channel 3 App: 1.2.0 | Drv COM: 1.7 | Drv DLL: 2.6

We now have successful communications with the base station so we can now pair with our device or we can select the Spectrum Analyser mode or Data Provider Monitor mode.

To connect to our device we will pair. This is achieved by power cycling the device. Pairing removes the need to know the radio settings of the device you are connecting to and also ensures that it is in a suitable state for configuration.

### Pairing Procedure

- Remove power from the acquisition module
- Click the Pair button on the toolkit.
- You now have 10 seconds to re-apply power to the acquisition module.

If you connect successfully the toolkit will change to the Information page.  
If the pairing fails try again.

---

**NOTE:** Pairing with the toolkit will **not** change the radio configuration settings of the connected device.

---

## Analyser

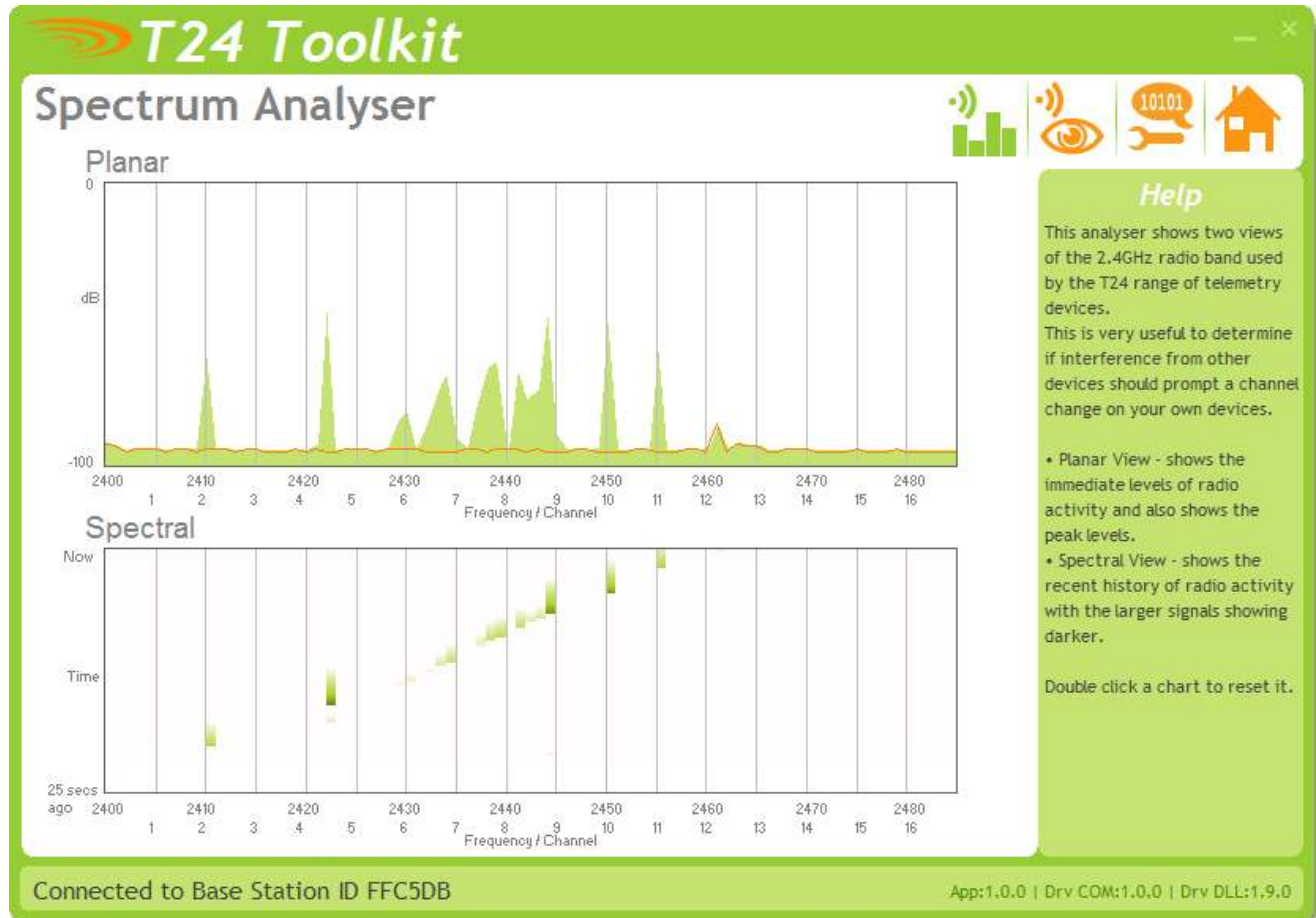

The analyser page is provided as a tool and will not normally be needed unless you plan to change channels and want to find the best channel to select, or to diagnose poor communications issues.

This page shows the radio signal levels detected across all the channels available to the T24 series of devices. Using this tool may help in detecting noisy areas and allow you to decide on which channels you may want to use.

The above charts show the traffic from a Wi-Fi network and it can be seen to be operating over channels 6 to 9 and it would be best (though not essential) to avoid using these channels.

## Data Provider Monitor

Data Tag	Total	Per sec	LQI	Value
C629	18	3	100	0.0160147
C623	58	10	100	0.0129487
C628	18	3	100	0.0218671
C62C	18	3	100	0.0152698
C627	17	3	100	0.0172869
C624	17	3	100	0.0130830

Select the devices you wish to log from the above list by checking them. Pressing the Start Logging button will allow you to select a filename to log the data to.

[View Last Log](#) [Start Logging](#)

Connected to Base Station ID FFC5DB App:1.0.0 | Drv COM:1.0.0 | Drv DLL:1.9.0

### Help

This page allows you to monitor Data Provider packets. Data Provider packets are what acquisition devices transmit periodically.

You have the option of logging these to a comma separated value (CSV) file.

*T24 acquisition devices normally operate in low power mode and periodically transmit Data Provider packets*

*This page shows all detected Data Provider packets which may be useful for checking that a device is operational.*

NOTE: When the toolkit connects to a device to enable configuration it will usually inhibit the transmission of Data Provider packets.

The Start Logging button will ask for a filename and proceed to log the received data to a CSV file in the following format:

**Data Tag, Elapsed mS, Value**

The View Last Log button will launch the application associated with CSV files and open the last logged file.

## Information

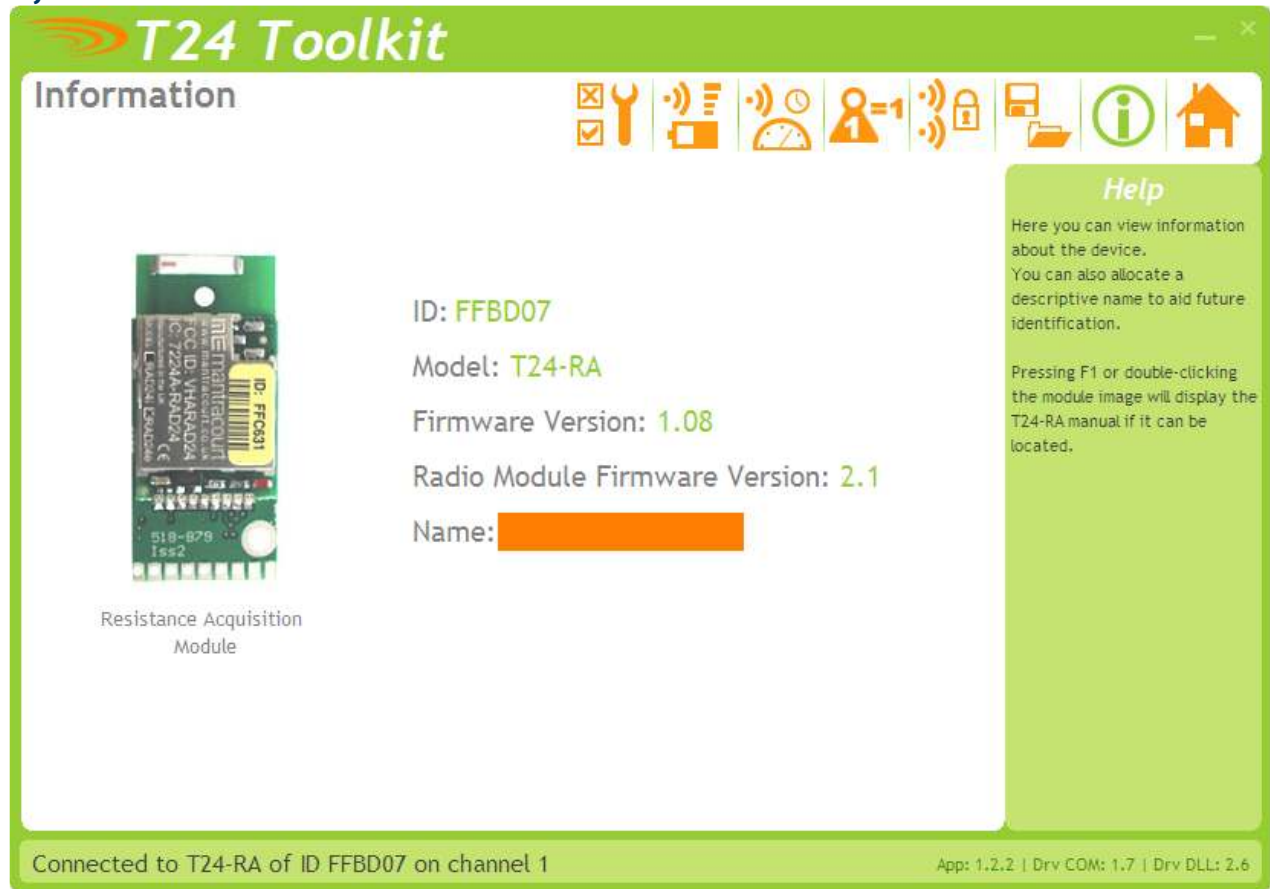

The screenshot shows the 'Information' page of the T24 Toolkit. The page has a green header with the 'T24 Toolkit' logo and a navigation bar with icons for various functions. The main content area displays the following information:

- ID:** FFBD07
- Model:** T24-RA
- Firmware Version:** 1.08
- Radio Module Firmware Version:** 2.1
- Name:** [Redacted]

On the left, there is an image of the Resistance Acquisition Module with the text 'Resistance Acquisition Module' below it. On the right, there is a 'Help' section with the following text:

**Help**  
Here you can view information about the device.  
You can also allocate a descriptive name to aid future identification.  
  
Pressing F1 or double-clicking the module image will display the T24-RA manual if it can be located.

At the bottom of the window, a status bar indicates: 'Connected to T24-RA of ID FFBD07 on channel 1' and 'App: 1.2.2 | Drv COM: 1.7 | Drv DLL: 2.6'.

Once successfully paired to a device this page is displayed.  
This page shows you information about the connected device.

### Items you can change:

**Name** You can enter a short description which may help you recognise this device in the future.

## Battery and Radio Levels

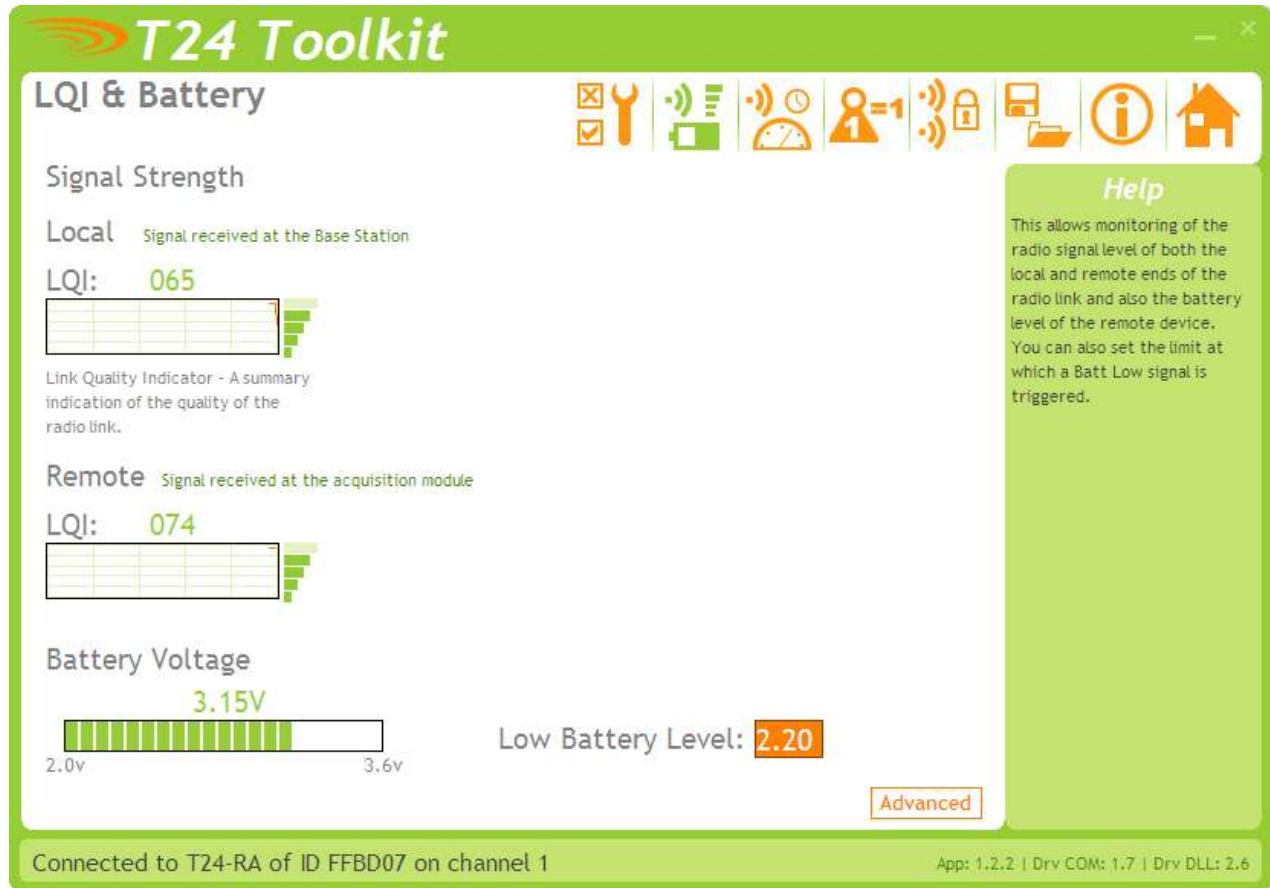

Here you can see the voltage of the battery and the radio signal levels at the base station and the remote acquisition module. This simple view gives an LQI value which stands for Link Quality Indicator. This value will range from 0 to 100 and within this band you should still achieve communications. As the level drops towards zero communications may become intermittent but still achievable.

You can set the level at which the acquisition module reports a low battery. If the battery voltage is below the Low Battery Level the bar will be coloured orange.

### Items you can change:

Low Battery Level                      Click this item to set the battery low level.

Clicking the Advanced button will give more detailed information on the RSSI and CV levels of the received radio packets.

## Battery and Radio Levels Advanced Settings

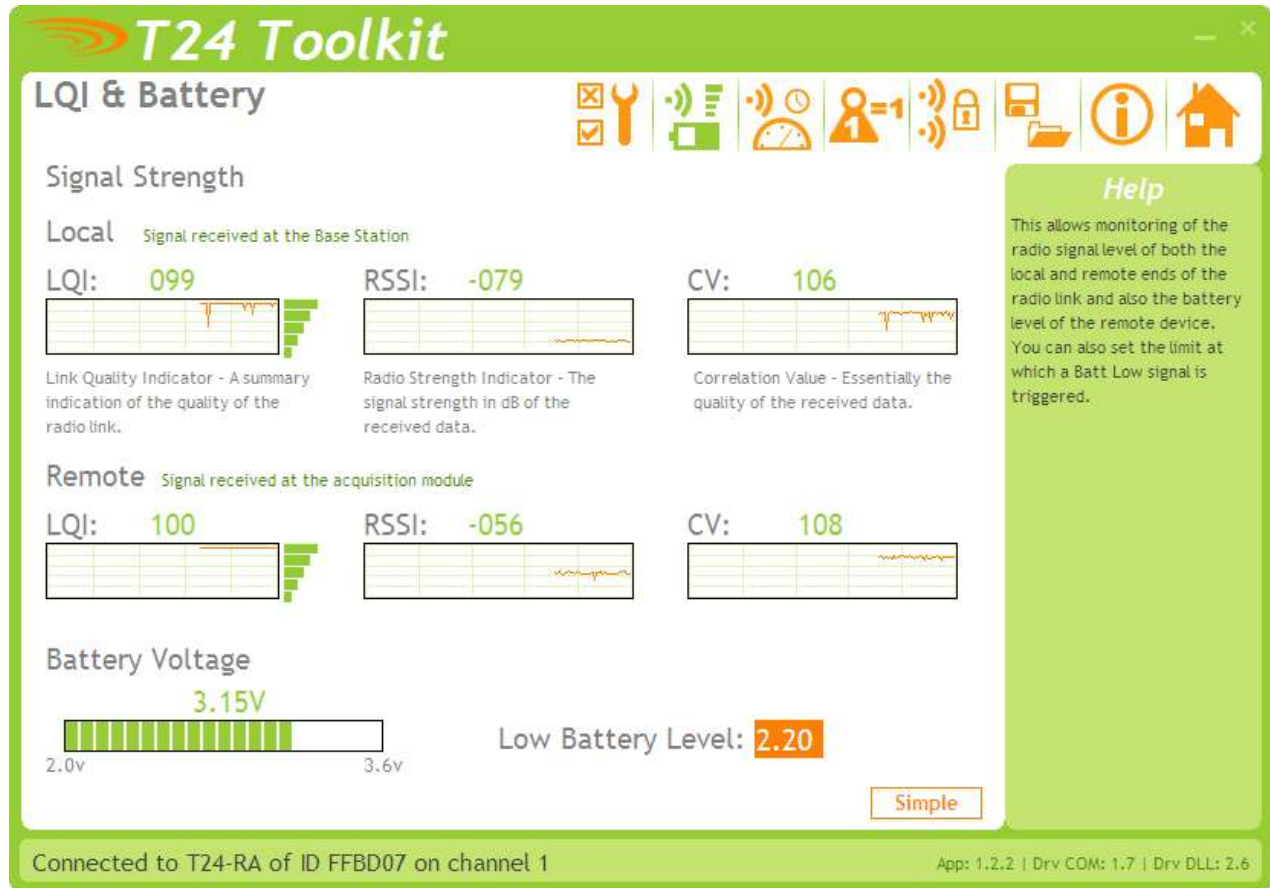

**LQI** value which stands for Link Quality Indicator. This value will range from 0 to 100 and within this band you should still achieve communications. As the level drops towards zero communications may become intermittent but still achievable.

**RSSI** is effectively the received dB level which will range from about -30 which is a good signal to -90 which is a weak signal.

**CV** is the correlation value and indicates how well the signal can be decoded. This ranges from 55 which is a poor quality signal and 110 which is an excellent signal.

## Data Rates and Quality

**T24 Toolkit**

### Data Rate

**Transmit Interval (ms)**  
333 Enter the interval between taking a measurement and transmitting the result. Default = 300

**Sample Time (ms)**  
5 The longer the sample time the more accurate the readings but the less life will be achievable from the battery. Default = 5

**Low Power Mode**  
Yes When Low Power mode is active the device semi-sleeps between transmissions so battery life is vastly increased. Default = Yes

#### Battery Life Guide

**Battery Type** Select a common battery type or enter a custom capacity.  
2 X Alkaline AA Cell 1.5V (Varta 4006)

**Usable Capacity (Ah)**  
2.3

**Sensor Impedance (Ohms)**  
1000

**Usage Per 24 Hour Period (Hours)**  
24.00

Noise Free Resolution: **Not Applicable**  
Battery Life: **28 days and 21 hours**

**Help**  
Here you can adjust data rates and quality and see the effect your choices have on battery life.  
The battery life guide is only an indication of battery life and there are many factors that can affect this which are not accounted for here.  
The guide assumes ideal operating conditions at 20 degrees centigrade and that capacitor modules are fitted when using alkaline batteries.  
Please refer to device manual for more information.

Connected to T24-RA of ID FFBD07 on channel 1 App: 1.2.2 | Drv COM: 1.7 | Drv DLL: 2.6

This page allows you to select the rate at which data is transmitted from the acquisition module and the quality. By selecting low power mode and entering some other information the toolkit will also give guides on achievable battery life.

Note that the battery life calculator is assuming the best case scenario which is at 20°C and that the battery has a suitable low internal resistance or that a suitable capacitor is fitted across the battery. See battery details in the Installation section.

#### Items you can change:

- |                   |  |
|-------------------|--|
| Transmit Interval | Enter the transmission rate in milliseconds. The default is 300 giving approximately 3 per second which is ideally suited to reading on a handheld. You may want to slow this down to achieve longer battery life.   |
| Sample Time       | This is the length of time in milliseconds that the input is sampled before the value is transmitted. This can vary between 5 milliseconds and close to the Transmit Interval. A shorter sample time means that the device is awake for less time so battery life is increased but at the expense of a reading with less noise free resolution. You can vary this to see the effect on battery.        |
| Low Power Mode    | Unless the acquisition module is non battery powered this should be set to Yes. In between transmissions the acquisition module will enter sleep mode which, for some modules such as the strain gauge acquisition module, will have a massive effect on battery life.<br>A Reason for <b>not</b> using Low Power Mode would be if using the device in a Master-Slave arrangement with PC for example. |
| Battery Type      | This is not a parameter of the device but information used by the battery life guide. You can choose from some preset batteries or choose custom to allow  |

you to select your own battery capacity. See below. This will also offer to change the Battery Low Level if the level suitable for the chosen battery is not the level currently set.

Usable Capacity	<p>This is not a parameter of the device but information used by the battery life guide. This is the capacity of the battery in Amp Hours and has a profound effect on battery life calculations. This capacity needs to be calculated from battery manufacturer's data sheets to take into account that we can only use batteries down to 2.1 Volts so in the case of twin AA cells this would be 1.05 Volts.</p> <p>Generally the usable capacity will not be as high as that advertised by the battery manufacturer. Temperature and internal resistance of the battery are not taken into account in the guide.</p>
Sensor Impedance Ohms	<p>Although the Impedance will vary an estimate of the average sensor impedance will provide a good indication of battery life.</p>
Usage Per 24 Hour Period	<p>Enter the number of hours per 24 hour period that the T24-HS handheld will be turned on and communicating with an acquisition module.</p>

## Input / Output Configuration

**Calibration**  
Calibrate by applying known inputs

**Number of Calibration Measurement Points**  
2 Select the number of points you want to calibrate over.  
The firmware version in this module allows you to calibrate using up to 10 measurement points.

**Calibration Points**

1	0.0	Acquire	6	0.0	Acquire
2	0.0	Acquire	7	0.0	Acquire
3	0.0	Acquire	8	0.0	Acquire
4	0.0	Acquire	9	0.0	Acquire
5	0.0	Acquire	10	0.0	Acquire

To start again [Click Here](#) To perform System Zero [Click Here](#)

**% Input**  
0.0529  
Shows the input applied.  
[Resistance]  
[Format](#)

**Calibrated Value**  
0.0530  
Shows the calibrated value. This may not display correctly until you have Acquired the second point!  
[Format](#)

[By Cert.](#)  
[Advanced](#)

**Help**  
This page allows you to calibrate and linearise the device by applying a number of known loads.  
Simply select the number of calibration points you require and enter the required engineering unit value for each point then apply each load and click the [Acquire] link.  
NOTE: Clicking any of the [Acquire] links may invalidate any existing calibration and will remove any existing System Zero.

Connected to T24-RA of ID FFBD07 on channel 1 App: 1.2.2 | Drv COM: 1.7 | Drv DLL: 2.6

The module is factory calibrated to provide between 0% and 100% output value when the positive input varies between the negative and positive excitation.

Here you can calibrate the acquisition module and set a system zero if required.

This simple page allows semi-automated calibration where you can apply known inputs to calibrate.

This calibration includes linearization and is automatically applied.

See later for **By Cert** and **Advanced** page where you can adjust individual gains and offsets.

### Calibration Process

- Decide on how many points you will calibrate over.
- Decide what inputs will be applied (in ascending order) at each point.
- Enter the actual input (in the required units) that you want the module to read at each point.
- Now proceed to apply each input in turn (allowing a settle time) and click the **Acquire** button at that point. You can now apply the next input and click **Acquire** until all the points are completed.

The bottom of the page shows the **Input Value** and the **Calibrated Value**. Once the second point has been acquired this **Calibrated Value** should display the actual calibrated value.

**Items you can change:**

Number of Calibration Points	Enter the number of points you wish to calibrate over. In its simplest form you could select two for a linear calibration. For more complex calibrations which include linearization select three to nine points.
Point 1 - 9	For each point enter the engineering unit value that you want the acquisition module to report at the applied input. i.e. 1.67
Acquire 1 - 9	Click this button when the input has been applied and the reading has been allowed to settle. This will acquire the reading and allow you to move to the next points. You will be able to click the button again to re-acquire.
Start Again	Click here to restart the calibration.
System Zero	Once calibrated you may want to remove a fixed system value. In the case of a strain gauge input this may be the weight of a sling, shackle, load bed etc. Apply the required input and click here to set the system zero. The current input will be removed from subsequent readings so that the reading will be zero. To edit this value manually click the <b>Advanced</b> button. System Zero is stored in non-volatile memory in the acquisition module.
By Cert.	You can click the <b>By Cert</b> button to calibrate against a sensor calibration sheet. You just need to enter the input values and associated engineering unit required output value of at least 2 points. This will take you to a different screen.
Advanced	Clicking the advanced button will allow you to edit the gains and offsets for each available calibration point. This will take you to a different screen.

## Calibration By Certificate

**T24 Toolkit**

### Calibration

Calibrate by entering certificate info

**Number of Calibration Measurement Points**

**2** Select the number of points you want to use.  
The firmware version in this module allows you to calibrate using up to 10 measurement points.

#### Calibration Points

	%	Engineering Units		%	Engineering Units
1	0.0	0.0	6	0.0	0.0
2	0.0	0.0	7	0.0	0.0
3	0.0	0.0	8	0.0	0.0
4	0.0	0.0	9	0.0	0.0
5	0.0	0.0	10	0.0	0.0

Once you have entered the desired number of points click the Calibrate button. Please note that when you return to this page the numbers may not be those you last entered. The values entered and displayed are used ONLY when you click the Calibrate button and therefore cannot be used to verify current calibration settings.

To reset calibration back to factory defaults [Click Here](#)

**Calibrate**

**Back**

#### Help

This advanced page allows you to calibrate the module to the attached input by entering a list of engineering unit values against known inputs. This could be used, for example, to calibrate a loadcell from the manufacturers calibration certificate.

Connected to T24-RA of ID FFBD07 on channel 1 App: 1.2.2 | Drv COM: 1.7 | Drv DLL: 2.6

In some circumstances it may not be possible to apply inputs in which case the calibration can be entered manually from the calibration table or certificate without ever having to connect the input.

#### Items you can change:

Number of Calibration Points

Enter the number of points you wish to calibrate over. In its simplest form you could select two for a linear calibration. For more complex calibrations which include linearization select three to nine points.

Input Points 1 - 9  
( shown in this screenshot)

Enter the input point for which you will specify a required engineering output value

Engineering Units 1 - 9

Enter the required engineering unit output for the specified input value

Calibrate

Click this button to calculate and update the device calibration

## Calibration Advanced

**T24 Toolkit**  
Calibration Advanced  
Calibrate by manual entry

**Number of Calibration Points**  
2 Select the number of gain points you want to use.

**Rotary Limit**  
0.0 This is an advanced feature used for rotary potentiometer applications. Please see user manual before using a value other than zero.

**Calibration Points**

	%	Gain	Offset		%	Gain	Offset
1	0.0	1.0	0.0	6	0.0	1.0	0.0
2	100.0	1.0	0.0	7	0.0	1.0	0.0
3	0.0	1.0	0.0	8	0.0	1.0	0.0
4	0.0	1.0	0.0	9	0.0	1.0	0.0
5	0.0	1.0	0.0				

**System Zero**  
0.0 This shows the current System Zero value that is subtracted from the input value before it is displayed. You can manually change the value or set it to zero to remove the System Zero.  
To reset calibration back to factory defaults [Click Here](#)

**Help**  
This advanced page allows you to modify the internal calibration table directly.

[Back](#)

Connected to T24-RA of ID FFBD07 on channel 1 App: 1.2.2 | Drv COM: 1.7 | Drv DLL: 2.6

In some circumstances it may not be possible to apply inputs in which case the calibration can be entered manually.

For example, if a sensor manufacturer provides a calibration table for a cell it may be possible to calculate gains and offsets and enter these values into the Advanced Calibration page without having to connect the input sensor.

### Items you can change:

Number of Calibration Points

Enter the number of points you wish to calibrate over. In its simplest form you could select two for a linear calibration. For more complex calibrations which include linearization select three to nine points.

Input Points 1 - 9 (mV/V shown in this screenshot)

Enter the input point to which the associated interpolated gain and offset values will be applied. Note between points the gain and offset values are linearly interpolated. Inputs are extrapolated below point 1 and above point 9.

Gain 1 - 9

Enter the gain value for associated point

Offset 1 - 9

Enter the Offset value for associated point

Rotary limit

This is the value at which the input will move from maximum to minimum value. This is useful for applications where the potentiometer input is endless i.e. moves from the maximum to the minimum as it wraps round. This parameter stops the unit reporting values outside the viable input range.

System Zero

You can set the system zero value here or set it to zero to remove the system zero effect.

### **Description of Linearisation Calculations**

The input value is looked up in a table of points which is dependent on what the user has selected, starting from the bottom of the table. When a point is found to which the input is less than then this point and the previous point are used to extrapolate a gain and offset from. This leads to a resultant gain and offset which is applied to the mV/V values as follows.

$$\text{Value} = (\text{input} * \text{Resultant Gain}) - \text{Resultant Offset}.$$

## Channel and Encryption

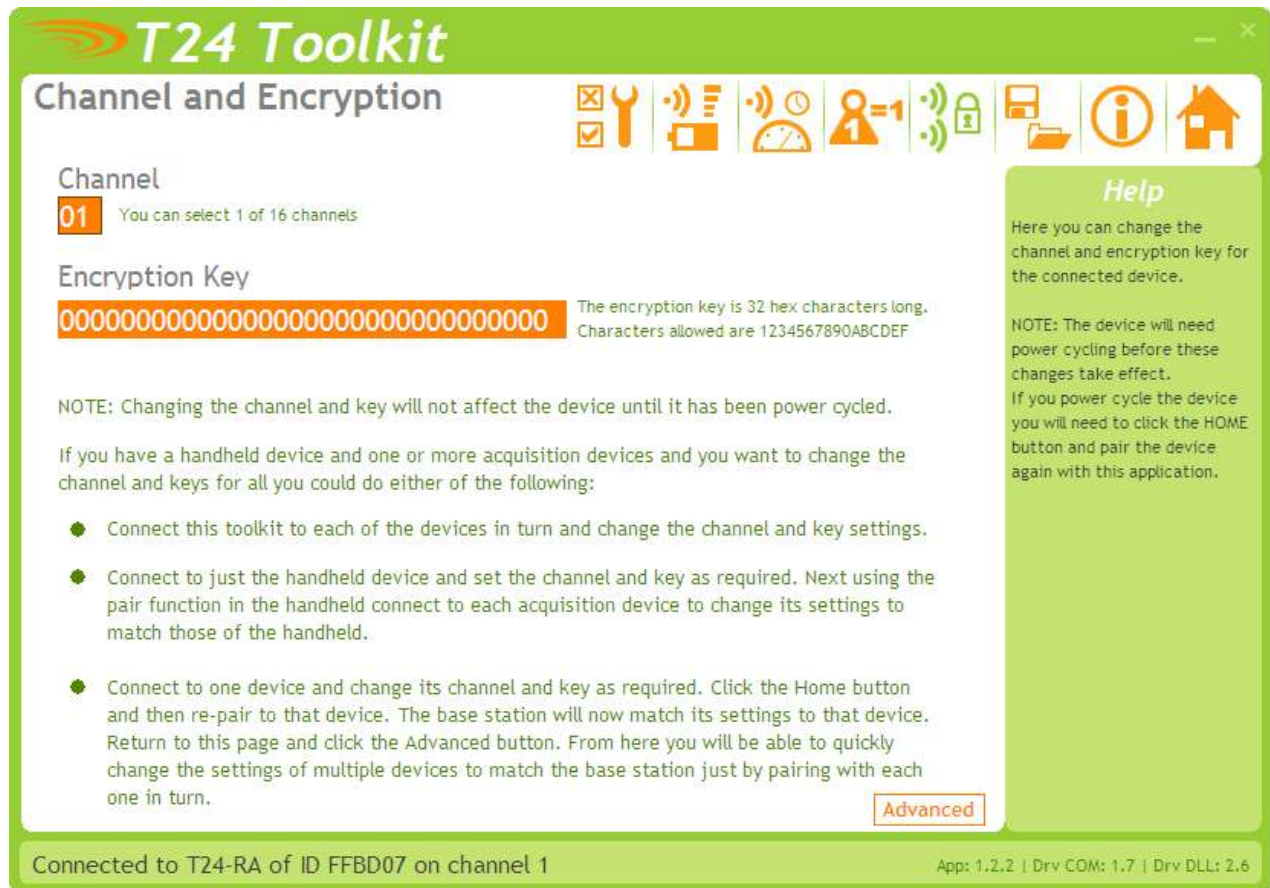

Here you can change the channel and encryption key for the acquisition module device.

If you want to change the channel of an acquisition module and T24-HS pair there is no need to change both devices.

Simply pair to the T24-HS handheld and change its channel and key.

Now perform pairing to the acquisition module from the handheld and the acquisition module will be configured to match the handheld.

NOTE: Early acquisition module do not yet utilise the encryption keys so these should be left at all zeros.

### Items you can change:

#### Channel

Select a channel between 1 and 16. The default is channel 1. You can use the Spectrum Analyser mode to determine a good clean channel to use.  
NOTE: Channel 16 is used to negotiate pairing so avoid this channel if possible.

#### Encryption Key

Only devices with identical encryption keys can communicate. You can isolate groups of devices on the same channel or just use the key to ensure the data cannot be read by somebody else.

## Save and Restore

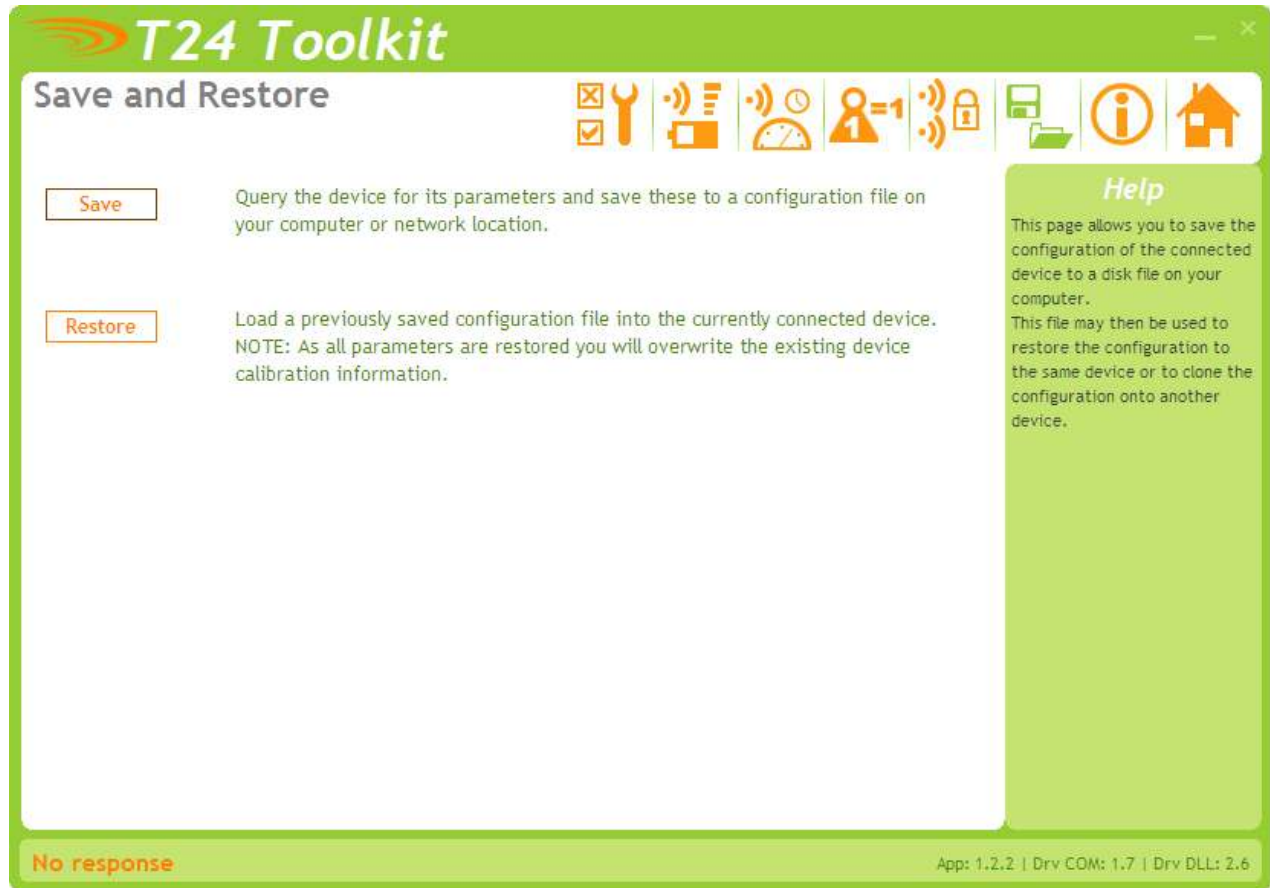

Here you can save the device settings to a file on your PC so that they can be later loaded back into the same or different device.

### Items you can change:

Save

Click this button to open a file dialog window to allow you to select a filename and location to save the configuration file to. All configuration information including calibration data will be saved to the file. The file extension is **tcf**.

Restore

Click this button to open a file dialog window to allow you to select a filename and location of a previously saved file to load into the connected device. All configuration information **including** calibration data will be overwritten. The file extension is **tcf**.

Advanced Settings

Click this button to enter the Advanced Settings Page. Here are settings which do not normally require changing.

## Advanced Settings

**T24 Toolkit**  
Advanced Settings

**Sleep Delay (s)**  
0 Enter a time in seconds after which without receiving a 'Keep Awake' message the device will enter deep sleep where no transmissions will occur again until the device is woken.

**Data Tag**  
BD07 This identifies the data transmissions and should only be changed under instruction. If this is changed then you would need to pair the device again with any reliant modules such as handhelds.

**Startup Time (ms)**  
0 When operating in low power mode this time entered in milliseconds determines how long to wait before beginning the sample time that takes measurements. This is to allow some input sensors powered by the acquisition module to power up before the input is sampled. Strain gauge inputs do not require this delay so should be set to zero. Use this setting with caution as this can seriously affect battery life!

**LED Mirror To Digital Output**  
No When set to True the state of the LED will be mirrored on the digital output. You may not be able to change this setting from No to Yes on devices that do not support this feature.

**Transmit Power (%)**  
100 Enter the transmission power level in percent. default is 100%

**Help**  
These are advanced settings and do not normally require changing.

Connected to T24-RA of ID FFBD07 on channel 1 App: 1.2.2 | Drv COM: 1.7 | Drv DLL: 2.6

You should not normally need to change these settings.

### Items you can change:

- Sleep Delay** Here you can enter a delay in seconds after which the acquisition module will return to deep sleep if no Keep Awake message is heard from the T24-HS handheld. The default is 60 seconds.
- Data Tag** The data transmitted by the acquisition module is marked with a Data Tag which is a 2 byte hexadecimal code. By default this is set to the last 2 bytes of the device ID (or to put it another way, the last 4 characters of the device ID). If by some chance you had two acquisition module devices that would be working on the same channel and had the same last 4 characters in their ID (1 in 65,535 chances) you may want to change the data Tag of one of the devices and perform pairing again with the T24-HS handheld.
- Startup Time** Some acquisition modules power a sensor from their excitation voltage. When coupled to a sensor with a slow startup time this setting is used to delay the measurement after wakeup from sleep between readings. This gives the sensor time to settle at the expense of battery life. For strain gauge inputs this settings should be zero.
- LED Mirror to Digital Output** When set to Yes each time the LED is active the digital output is active. This can be useful if the module is to be encapsulated or enclosed and enables a second LED to be externally mounted. This is very useful when using a T24-HR roaming handheld as the acquisition module LED will activate while the handheld is in communications with the module.
- Transmit power** Set the transmit power level from 0 - 100%. Default is 100%

## Installation

### Overview

Radio performance at microwave wavelengths is very dependent upon the operating environment; any structure within the operating region of the radios will give rise to three effects:

**Obscuration.** Obscuration will result in reduced range and occurs when an obstruction masks the line-of-sight between radios.

**Aberrations to the horizontal and vertical space patterns.** Distortion of these patterns may occur if structures or objects are placed in the near or intermediate field of the antenna. The effect will be to distort the coverage patterns, adversely affecting range and link quality.

**Reflection.** Any object placed in line-of-sight of the transmit antenna will result in signals arriving at the receiver by an indirect path. Degradation of performance due to reflection (multipath effects) appears as reduced range or poor link quality.

Any of the above will cause poor RSSI figures, an increase in the packet loss rate and in extreme cases complete loss of signal. Fortunately, if consideration is given to these effects at the integration stage then a good quality link will be obtained.

#### **Guidelines for product design:**

When selecting materials for product enclosures, preference should be given to fibreglass, light coloured ABS or Polypropylene; at the wavelength of 2.4GHz radio other materials will adversely affect the signal by attenuation, refraction or change in polarisation.

If the application demands that the radio is fitted inside a metal enclosure then ensure that the specified clearances are maintained around the antenna and design in a fibreglass RF window at least as large as the clearance dimensions but ideally as large as possible.

RAD24i radios fitted inside a product should be oriented so that the chip antenna will be vertical when the product is in its normal operating position.

#### **Guidelines for installation:**

When planning installations ensure that line-of-sight between nodes is maintained and that objects or structures are kept at least one metre away from antennae wherever possible.

To avoid poor link quality between a RAD24i radio and a handheld device ensure that the RAD24i is mounted so that the chip antenna is vertical. Improvement may also be obtained by altering the height above ground of the RAD24i; a small increase or reduction in antenna elevation will often improve reception.

Range underwater is only a decimetre or so depending on packet rate. Best performance underwater is obtained by using low packet rates and immersing water-proofed antennae rather than water-tight enclosures containing the antennae.

## Power Supply / Battery

The acquisition module operates from 2.1 to 3.6 Volts dc so can be supplied from a variety of cells.

**WARNING: It is important to note that the acquisition module is NOT reverse polarity protected!**

**WARNING: The maximum voltage is 3.6V!**

---

### Considerations When Selecting Batteries

#### Re-chargeable or replacement

This really depends on the application. Some applications where expected battery life with alkaline batteries will be many years would probably not warrant the use of re-chargeable batteries. Re-chargeable batteries have implementation issues such as how to connect to the charger, how to seal this connection if required, can the batteries be re-charged at a convenient point in the operation of the device I.E between shifts and does the voltage, when charging, exceed the maximum supply voltage of the acquisition module if so the inline charging module will need to be fitted.

#### Required battery life

Driven by the application and mainly dependent on measurement rate and sample time. The operation would normally require that the acquisition module is used in Low Power Mode to maximise battery life.

#### Size of

Choosing a battery will be influenced by how much space is available and what battery life is required, generally the bigger the battery the longer it will last.

#### Operating temperature range

A batteries useable capacity is influenced by its operating temperature. Generally, the lower the temperature the lower their ability to provide charge. Beware of the batteries specified operating range when considering a particular battery technology.

#### Self discharge.

Batteries are chemical devices and have a shelf life which needs to be considered in application where long battery life is required. Typically an Alkaline has a battery life of 5 years.

#### Internal Resistance of battery

Low internal resistance is important, the higher the resistance the less useful life of the battery is available. This is due to voltage drops caused during the high current phase of the measurement cycle. Batteries with an internal resistance of less than 150mOhm will not require the additional inline capacitor module.

#### Connections to battery

For the same reasons internal resistance must be low it is important to keep any voltage drops from the battery to the acquisition module as low as possible too. Care must be taken in selecting the connection method between batteries and acquisition module. For example cables should be kept as short and thick as possible.

#### Environmental

Other considerations when selecting a connection method to the Batteries is the effect of vibration. A standard battery holder is a poor choice in applications when the device can be subject to vibration. This is due to the interruption of supply from the battery to the acquisition module caused when the spring arrangement holding the battery to the terminal of the holder is defeated.

Corrosion of terminals must also be considered as this will also introduce resistance into the supply connections. This could be overcome by ensuring the enclosure is sealed.

#### Optimising battery life

Battery life can be optimised by considering the following.

- Use of low power mode.
- Transmission interval.
- Required Measurement resolution (Sample time).
- Sleep / Wake configuration
- Auto-Sleep duration.

## Battery Types

Battery Type	Notes
Alkaline Zn-MnO <sub>2</sub>	Pairs of alkaline 1.5V cells are the most common. Use D cells for maximum life and AA cells where space is restricted. Example: Varta 4014 (D), Varta 4006 (AA) <b>Recommend T24-BC2 module</b> to maximise usable capacity.
Nickel Metal Hydride NiMh	Most cells are 1.2V so two in series gives 2.4 Volts. These can match alkaline batteries in capacity but as the charged voltage is lower they do not match the usable capacity. These batteries self discharge at a faster rate than alkalines. If charging these cells in circuit precautions must be taken to ensure that the maximum voltage on the acquisition module is not exceeded. Example: GP 270AAHC (AA) <b>Recommend T24-BC2 module</b> to maximise usable capacity.
Nickel Cadmium NiCad	Most cells are 1.2V so two in series gives 2.4 Volts. Three in series can be used to give 3.6 Volts. These do not have the usable capacity of an alkaline battery. These are generally only useful if they are to be charged on a regular basis. If charging these cells in circuit precautions must be taken to ensure that the maximum voltage on the acquisition module is not exceeded. Example: <b>Recommend T24-BC2 module</b> to maximise usable capacity.
Lithium Primary 3.6V Li-SOCl <sub>2</sub>	Lithium cells can be used but note that the maximum voltage is 3.6 Volts. Select a cell with low internal resistance. Example: Saft LS17500 (A), Saft LSH20 (D) <b>Recommend T24-BC1 module</b> as these cells usually have a high internal resistance.
Lithium Iron Disulphide Li-FeS <sub>2</sub>	These can be found at 1.5 Volts and can therefore be a direct replacement for Alkaline cells. The low internal resistance and high capacity make these batteries an ideal choice. Example: Energizer L91
Lithium Ion and Lithium Polymer LiON, LiPo	These generally start at 3.7V and exceed the maximum allowable voltage. These are usable if a regulator and charging circuit can be installed between the acquisition module and the battery. Care must be taken here that the regulator does not draw too much current when idle so that the low power modes are not compromised. <b>Recommend T24-BC1 module.</b>

## Power Supply Modules

### Lithium Ion /Polymer Module T24-BC1

The T24-BC1 is a battery charger and power supply suitable for the T24 range of 3V acquisition modules. The T24 Battery Charger is designed to supply a constant 3.3V from a Li-ion Battery while also charging the battery from an input voltage. The unit comes pre-configured to provide a charging current of 466mA suitable for VARTA LIP653450. This module also supports additional batteries providing a charge current of 133mA via the removal of the leaded resistor (non surface mount).

## Physical Connections

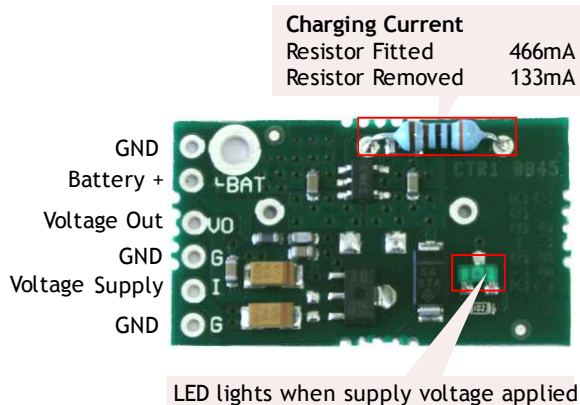

## Specification

Parameter	Min	Typ	Max	Units
Supply Voltage	4.1	5	6	V
Regulated Voltage Output	-	3.3	-	V
Battery positive connection	-	3.7	-	V
Maximum Cable Length	-	-	150	mm
Quiescent Current	-	1.7	-	µA

Note LED will only be lit when an input voltage is applied

## Suitable Batteries

### VARTA LIP653450

- Rated Capacity: 1100mAh
- Dimensions: 35 x 54 x 7 (mm)
- Weight: 20g
- Charge Time : 3 Hours @ 466mA
- Battery life = 1 month 25 days\*



### VARTA LIC18650

- Rated Capacity: 2200mAh
- Dimensions: 18.25 Diameter 65mm Height
- Weight: 46g
- Charge Time : 4.5 Hours @ 466mA
- Battery life = 3 months 20 days\*



### UBC 581730

- Rated Capacity: 250mAh
- Dimensions: 18 x 31.5 x 5.8 (mm)
- Weight: 6.5g
- Charge Time : 2 Hours @ 133mA
- Battery life = 12 days 13 hours\*



\* Note: Battery life is calculated with a T24-RA running in low power mode with a sample time of 5mS and transmit interval of 333mS and an input impedance of 1000 Ohms for 2 hours out of every 8 hours.

### **Capacitor Module T24-BC2**

This is used for batteries which have an internal resistance of greater than 150mOhms overcoming voltage drops during high current phases of the low power mode cycle.

This problem becomes apparent when attempting to communicate with high peak current acquisition modules such as a T24-PA using the T24 Toolkit or power cycling when the battery is near the end of its life. In normal operation (Low power mode) with a handheld T24-HS where the T24-PA is connected to an uninterrupted battery this module is generally not required.

Using lower impedance strain gauges (or multiple parallel strain gauges) exacerbates this problem.

Consult Sales for details. Alternatively fit an electrolytic capacitor across battery of 2000uF or greater. This capacitor should be of low ESR (< 70mOhms).

## Mounting

### Mechanical size

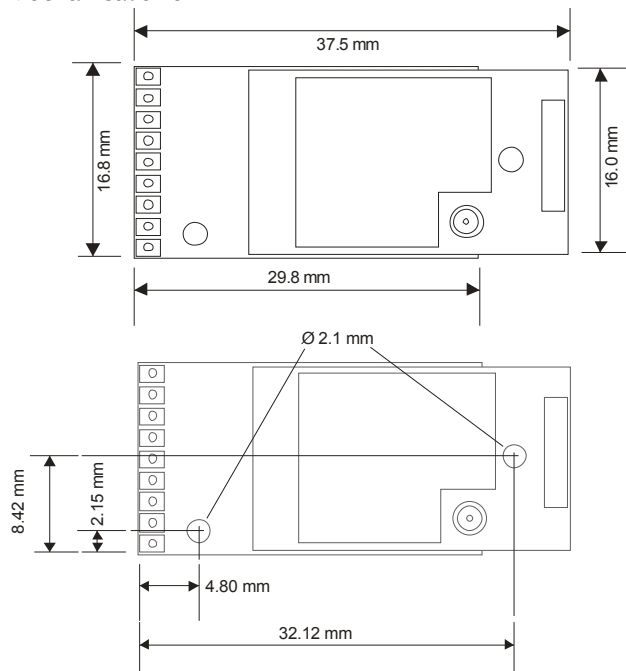

There are two holes available for mounting. The one nearest the connection pads can accept an M2 screw or American equivalent #0-80. Important Note: DO NOT USE #2 screw size. Note that the mounting hole is connected directly to the Battery ground of the acquisition module.

The mounting hole near the chip antenna cannot accept metal mounting hardware.

The connection holes are on a 1.9mm pitch and are a diameter of 1mm.

## Antenna

### Internal Chip Antenna

There must be no metal objects within 7mm of the antenna's long edge and 20mm from the short edges. See diagram below

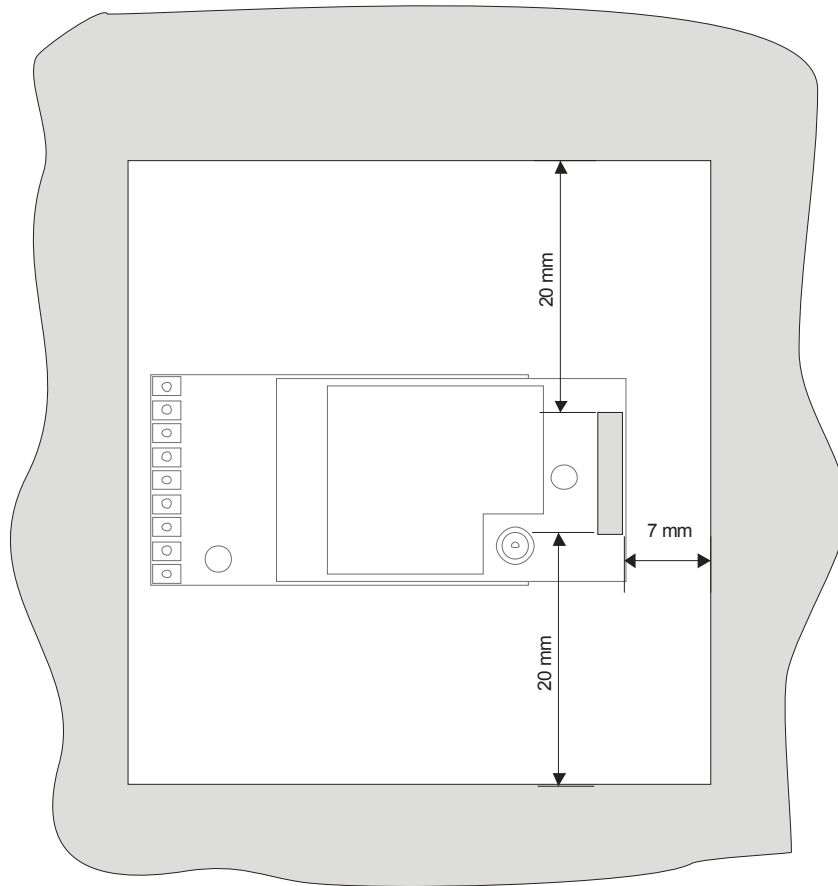

## External Antennas

The external antennas come in two styles.

The flat PCB antenna can be mounted inside a plastic housing or to the outside of a metal housing. The PCB requires 3mm Clearance on all edges, this also applies to the RF window.

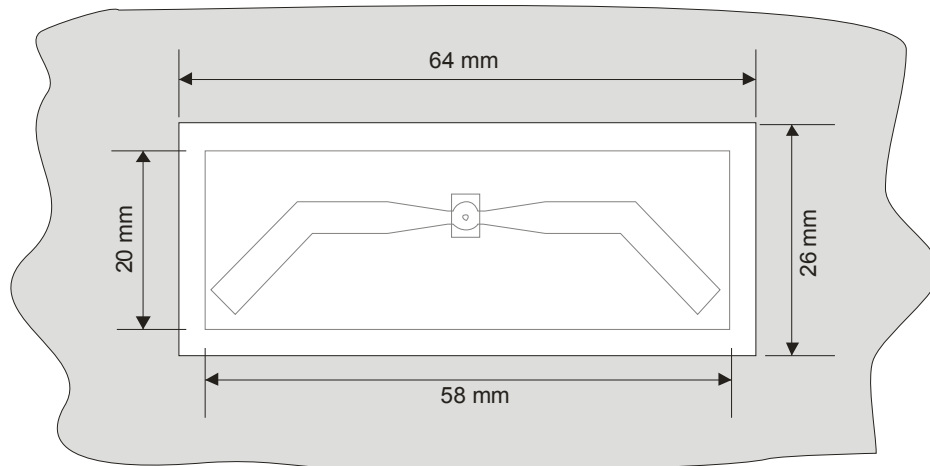

The bulkhead mounting antenna can be used with metal or plastic housings. Care must be taken when mounting the Antenna to ensure the installation does not become directional.

## Antenna Orientation

For the maximum range the acquisition module and any other modules should be orientated as shown.

The sensitivity to the radio transmission will be reduced if the acquisition module is oriented in a vertical or portrait position if a handheld is used because the handheld can only be used in one orientation.

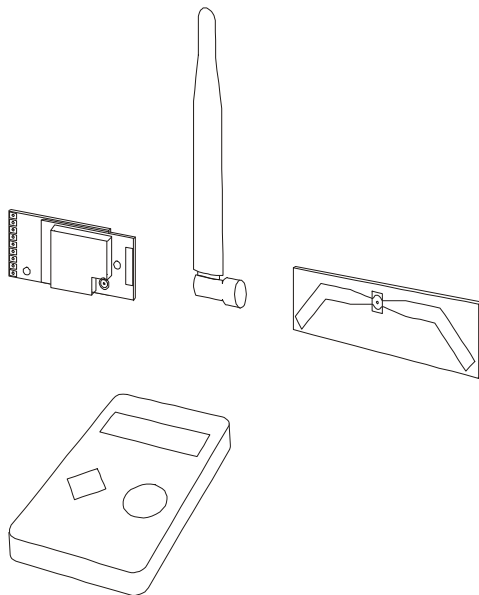

## Specifications

### General Radio

	Min	Typical	Max	Units
License		License Exempt		
Modulation method		MS (QPSK)		
Radio type		Transceiver (2 way)		
Data rate		250		K bits/sec
Radio Frequency	2.4000		2.4835	GHz
Power		1		mw
Range RAD24i (Integrated antenna)			120 (400)	Metres (feet) *
Range RAD24e (External antenna)			200 (650)	Metres (feet) *
Channels (DSSS)		16		

\* Maximum range achieved in open field site with T24-RA at a height of 3 metres (9.8 feet) above ground and T24-HS held at chest height pointing towards the T24-RA.

### T24-RA

Specification at 3V supply at 25 °C

Measurement	Min	Typical	Max	Units
Sensor Excitation Voltage	2.4	2.5	2.6	VDC
Input Range	500		100,000	Ohms
Accuracy		0.01		% of Full Scale

Electrical	Min	Typical	Max	Units
Power Supply voltage	2.1	3.0	3.6	V dc
Power Supply ripple			50	mV ac pk-pk

Power Supply current	Min	Typical	Max	Units
Normal Mode		35	65	mA
Standby / Low power mode		5	40	uA

Environmental	Min	Typical	Max	Units
Operating temperature range	-40		+85	°C
Storage temperature	-40		+85	°C
Humidity	0		95	%RH

Physical	
PCB Dimensions	16.8 x 37.5 x 6.5mm

## Approvals

CE



Complies with EMC directive. 2004/108/EC

The Radio Equipment and Telecommunications Terminal Equipment (R&TTE) Directive, 1999/5/EC,

### European Community, Switzerland, Norway, Iceland, and Liechtenstein

- English: This equipment is in compliance with the essential requirements and other relevant provisions of Directive 1999/5/EC.
- Deutsch: Dieses Gerät entspricht den grundlegenden Anforderungen und den weiteren entsprechedenen Vorgaben der Richtlinie 1999/5/EU.
- Dansk: Dette udstyr er i overensstemmelse med de væsentlige krav og andre relevante bestemmelser i Directiv 1999/5/EF.
- Español: Este equipo cumple con los requisitos esenciales asi como con otras disposiciones de la Directive 1999/5/EC.
- Français: Cet appareil est conforme aux exigences essentielles et aux autres dispositions pertinentes de la Directive 1999/5/EC.
- Íslenska: Þessi búnaður samrýmist lögboðnum kröfum og öðrum ákvæðum tilskipunar 1999/5/ESB.
- Italiano: Questo apparato é conforme ai requisiti essenziali ed agli altri principi sanciti dalla Direttiva 1999/5/EC.
- Nederlands: Deze apparatuur voldoet aan de belangrijkste eisen en andere voorzieningen van richtlijn 1999/5/EC.
- Norsk: Dette utstyret er i samsvar med de grunnleggende krav og andre relevante bestemmelser i EU-directiv 1999/5/EC.
- Português: Este equipamento satisfaz os requisitos essenciais e outras provisões da Directiva 1999/5/EC.
- Suomalainen: Tämä laite täyttää direktiivin 1999/5/EY oleelliset vaatimukset ja on siinä asetettujen muidenkin ehtojen mukainen.
- Svenska: Denna utrustning är i överensstämmelse med de väsentliga kraven och andra relevanta bestämmelser i Direktiv 1999/5/EC.

This equipment is in compliance with the essential requirements and other relevant provisions of Directive 1999/5/EC.

FCC



Family: RAD24

Models: i and e for internal and external antenna variants. For antenna T24-ANTA and T24-ANTB

FCC ID:VHARAD24

This device complies with Part 15c of the FCC Rules. Operation is subject to the following two conditions: (1) this device may not cause harmful interference, and (2) this device must accept any interference received, including interference that may cause undesired operation.

**CAUTION:** If the device is changed or modified without permission from Mantracourt Electronics Ltd, the user may void his or her authority to operate the equipment.

## Industry Canada



Models: i and e for internal and external antenna variants. For antenna T24-ANTA and T24-ANTB

IC:7224A-RAD24

This apparatus complies with RSS-210 - Low-power Licence-exempt Radiocommunication Devices (All Frequency Bands): Category I Equipment RSS.

## OEM / Reseller Marking and Documentation Requirements

### FCC

The Original Equipment Manufacturer (OEM) must ensure that FCC labelling requirements are met. This includes a clearly visible label on the outside of the final product enclosure that displays the contents as shown:

Contains FCC ID:VHARAD24

This device complies with Part 15 of the FCC Rules. Operation is subject to the following two conditions:

- (1) this device may not cause harmful interference and
- (2) this device must accept any interference received, including interference that may cause undesired operation.

The acquisition modules have been tested with T24-ANTA and T24-ANTB. When integrated in OEM products, fixed antennas require installation preventing end-users from replacing them with non-approved antennas. Antennas other than T24-ANTA and T24-ANTB must be tested to comply with FCC Section 15.203 (unique antenna connectors) and Section 15.247 (emissions).

Acquisition modules have been certified by the FCC for use with other products without any further certification (as per FCC section 2.1091). Changes or modifications not expressly approved by Mantracourt could void the user's authority to operate the equipment.

In order to fulfil the certification requirements, the OEM must comply with FCC regulations:

1. The system integrator must ensure that the text on the external label provided with this device is placed on the outside of the final product.
2. The acquisition modules with external antennas may be used only with Approved Antennas that have been tested by mantracourt.

### IC

Labelling requirements for Industry Canada are similar to those of the FCC. A clearly visible label on the outside of the final product enclosure must display the following text:

Contains Model RAD24 Radio (2.4 GHz), IC:7224A-RAD24

Integrator is responsible for its product to comply with RSS-210 - Low-power Licence-exempt Radiocommunication Devices (All Frequency Bands): Category I Equipment RSS.

### CE

The T24 series has been certified for several European countries.

If the acquisition module is incorporated into a product, the manufacturer must ensure compliance of the final product to the European harmonized EMC and low-voltage/safety standards. A Declaration of Conformity must be issued for each of these standards and kept on file as described in Annex II of the R&TTE Directive.

Furthermore, the manufacturer must maintain a copy of the T24 device user manual documentation and ensure the final product does not exceed the specified power ratings, antenna specifications, and/or installation requirements as specified in the user manual. If any of these specifications are exceeded in the final product, a submission must be made to a notified body for compliance testing to all required standards.

#### OEM Labelling Requirements

The 'CE' marking must be affixed to a visible location on the OEM product.



The CE mark shall consist of the initials “CE” taking the following form:

- If the CE marking is reduced or enlarged, the proportions given in the above graduated drawing must be respected.
- The CE marking must have a height of at least 5mm except where this is not possible on account of the nature of the apparatus.
- The CE marking must be affixed visibly, legibly, and indelibly.

## ***Declaration Of Conformity***

We, Mantracourt Electronics Limited  
The Drive  
Farringdon  
Exeter  
Devon EX5 2JB

declare under our sole responsibility that our products in the **T24 Radio Telemetry Product Range** to which this declaration relates are in conformity with the appropriate standard EN 300 328 following the provisions of the Radio and Telecommunications Terminal Equipment Directive **1999/5/EC**, FCC CFR Title 47 part 15c BS EN 61000-4-2 and BS EN 61000-4-3 following the provisions of the EMC Directive **2004/108/EC** and Low Voltage Directive **2006/95/EC**.

December 2007



Brett James  
Development Manager  
Mantracourt Electronics Limited.

FCC ID:VHARAD24



## Worldwide Regional Approvals

Region	Product Conforms To
Europe	CE
USA	FCC
Canada	IC
Australia	To Be Determined
China	To Be Determined
Japan	To Be Determined

### Important Note

Mantracourt does not list the entire set of standards that must be met for each country. Mantracourt customers assume full responsibility for learning and meeting the required guidelines for each country in their distribution market. For more information relating to European compliance of an OEM product incorporating the T24 range of modules, contact Mantracourt, or refer to the following web site: [www.ero.dk](http://www.ero.dk)

## Warranty

All Telemetry products from Mantracourt Electronics Ltd., ('Mantracourt') are warranted against defective material and workmanship for a period of (1) one year from the date of dispatch.

If the 'Mantracourt' product you purchase appears to have a defect in material or workmanship or fails during normal use within the period, please contact your Distributor, who will assist you in resolving the problem. If it is necessary to return the product to 'Mantracourt' please include a note stating name, company, address, phone number and a detailed description of the problem. Also, please indicate if it is a warranty repair.

The sender is responsible for shipping charges, freight insurance and proper packaging to prevent breakage in transit.

'Mantracourt' warranty does not apply to defects resulting from action of the buyer such as mishandling, improper interfacing, operation outside of design limits, improper repair or unauthorised modification.

No other warranties are expressed or implied. 'Mantracourt' specifically disclaims any implied warranties of merchantability or fitness for a specific purpose. The remedies outlined above are the buyer's only remedies. 'Mantracourt' will not be liable for direct, indirect, special, incidental or consequential damages whether based on the contract, tort or other legal theory.

Any corrective maintenance required after the warranty period should be performed by 'Mantracourt' approved personnel only.



CE

In the interests of continued product development, Mantracourt Electronics Limited reserves the right to alter product specifications without prior notice.

DESIGNED & MANUFACTURED IN THE UK

Code No. 517-930

Issue 1.0

21.12.11