

Weighing Indicator/Controller for Loss in Weight

Features

- Fast & accurate fill control
- Auto calibration
- In Flight compensation
- Sufficient material check
- Auto tare
- Option for printer communications



Introduction

On pressing the start contact the hopper contents level is checked to confirm that sufficient material is available to fulfil the Set Point 1 value.

If this is correct, an Auto Tare occurs and the feed valve opens (relay 1) until Set Point is reached (SP-IF).

If on receiving a start input, the hopper level is less than the hopper low level (HLL) the feeding valve will be opened by relay 2, until the hopper high level (HHL) is reached. On reaching the high level a timer is started for a period set in

'Tl', after this period the discharge is started.

If a further start signal is received and product is now available, the result of more product in the hopper, then discharge can be initiated. The analogue output value is taken from the hopper gross value.

An optional printer will print the Set Point value of the target and actual achieved value, together with the bag number. With appropriate printers a Time and Date stamp can be given.

Specifications

Inputs

Calibration	Automatic digital by use of keypad and 1 (or 2) known weights. Manual calibration can also be selected	Sensitivity	Preset via DIL switches between 0.5 to 200mV/V
Auto Tare	By pressing keys '▶' and then 'R', display will zero. Auto tare value can also be viewed and manually changed if required. Auto tare value is retained on powerdown.	Excitation	10V DC nominal, 150mA maximum
		Compensation	By ± sense wires to compensate for cable, connection volt drops and any variation in 10V supply
		Accuracy	90 days ± 0.08% of reading ± 0.05% of FS typical
		Drift	0.002%/°C typical @ 2.5mV/V

Mnemonics Available

Mnemonic	Description	Mnemonic	Description
net	Live net value	At	As ADW15
gros	Live gross value of hopper weight	dA	Display averaging and select default display Net +(0 - 7), Gross + (8 - 15)
PASS	Password as ADW15 Discharge	OPL	As ADW15
SP	Set point	OPH	As ADW15
IF	Discharge in-flight	dP	As ADW15
HHL	Hopper high level	CP	As ADW15
HLL	Hopper low level	Sdst/Lab	As ADW15
tl	Time delay from hopper fill to start discharge set in seconds	Ln	As ADW15
St	Hopper settle time (set in seconds)	rS	As ADW15
CALL	As ADW15	Inp	As ADW15
CALH	As ADW15		

Note: The default display can be selected from the gross weight or the incremental net weight flowing into the receiving container

DC Analogue Outputs

Order Code	Range	Order Code	Range
V02	0 to 5V	A01	0 to 1mA
V04	0 to 10V	A02	0 to 20mA
V06	-10 to +10V	A03	4 to 20mA
Max Current out 50mA		Max Current out 50mA	
Accuracy	typical ± 0.08% of output, ± 0.08%FSD	Isolation	±130V RMS or DC max to analogue input or to any other port
Resolution	as display resolution, max 15 bits	Ranging	Fully keypad scalable over desired display range
Calibration	by 15-turn pre sets for gain and offset	PID	Power level, when selected = 12 bit resolution output
Inversion	By keypad value		

Communications Port CP Operation

All display data can be accessed via the communications port along with relay, PID power and EEPROM status.
All user configurable data can be changed including EEPROM enable/disable and relay reset (address code cannot be changed).

Communications Port

Order Code	Type	Details
COM1	RS485/422	For up to 32 instruments on 1 bus, 4 wire
S01	20mA	For up to 25 instruments per interface, 4 wire

Communications Port

Order Code	Type
COM1	RS485/422
S01	20mA

Cable length, 1km (depending on baud rate)

Baud rates, 300, 600, 1200, 2400, 4800, 9600 (19200 MANTRABUS only)

Electrical isolation, $\pm 130V$ RMS or DC max to analogue input or any other port

Formats, MODBUS RTU, MANTRABUS and printer output formats

Power Supplies

Order Code	Type
W240	220V-230V AC 50-60Hz 10W
W110	110V-120V AC 50-60Hz 10W
W12/24	9-32V DC 10W isolated

Base ADW15

Displays 7 segment LED 4.5 digit 10mm.3 x 3mm LED's 2 for relay status, 1 for program and hold indication.

Controls

4 membrane panel keys with tactile feedback. 1 scroll key to view/update parameter. 1 digit select key. 1 digit increment key. 1 reset key. Keypad disable by internal links behind front panel. Hold function by digit select key when in input mode.

Data Retention/Protection

Retention: 10 years for set up values, minimum of 100,000 write cycles.
Protection of data and function(s): Watchdog timer giving repeat auto resets. Impending power detection and hold off. Keypad security and time out.

CE & Environmental

Storage temperature	-20 to +70°C	EMC Emissions	BS EN 55011:1998
Operating temperature	-10 to 50°C	EMC Immunity	BS EN 61000-4-2:1995
Relative humidity	95% maximum non condensing		BS EN 61000-4-3:2002
Safety/Low Voltage	73/23/EEC amended by 93/68/EEC		BS EN 61000-4-4:2004
Directive	BS EN 61010-1:2001, IEC 1010-1:1990		BS EN 61000-4-11:2004
EMC Directive	89/336/EEC		
	Basic Standard BS EN 61326:1998		

Physical

Case Dimensions DIN 72 x 72 x 163mm (excluding mounting terminal)
Case Material Grey Noryl, flame retardant
Weight 750 grams
Terminals 2.5mm, saddle field terminals
Accessibility All electronics removable through front panel leaving field wiring and case in situ.

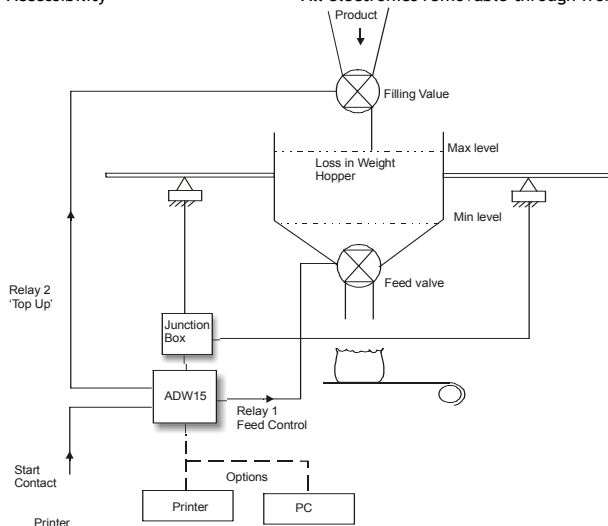

Designed, Manufactured & Supported in the UK



CE In the interest of continued product development, Mantracourt Electronics Limited reserves the right to alter product specifications without prior notice.