



ADW-LW

Weighing Indicator / Controller for Loss in Weight

Supplement to be read in conjunction with the ADW15 User Manual

User Manual
mantracourt.com

ME mantracourt

Contents

ADW-LW Loss in Weight	2
Brief Description	2
Operational Outline	2
Table 1	3
ADW Communications Commands/Mnemonics	3
(CP1 MANTRABUS Fast Format)	3
Table 2	4
Response To Command 1 From ADW	5
Table 3	5
Response To Command 2 From ADW	5
Table 4	5
CP2 (ASCII Format)	6
Table 5	6
Figure 2 ADW-LW Loss in Weight Procedure	7

ADW-LW Loss in Weight

The application is based upon the ADW15 Strain Gauge Amplifier, and this supplement should be read in conjunction with the ADW15 User Manual, with regard to:

- Calibration Procedures
- Analogue Output
- Scaling
- Relay Output Action
- Communications

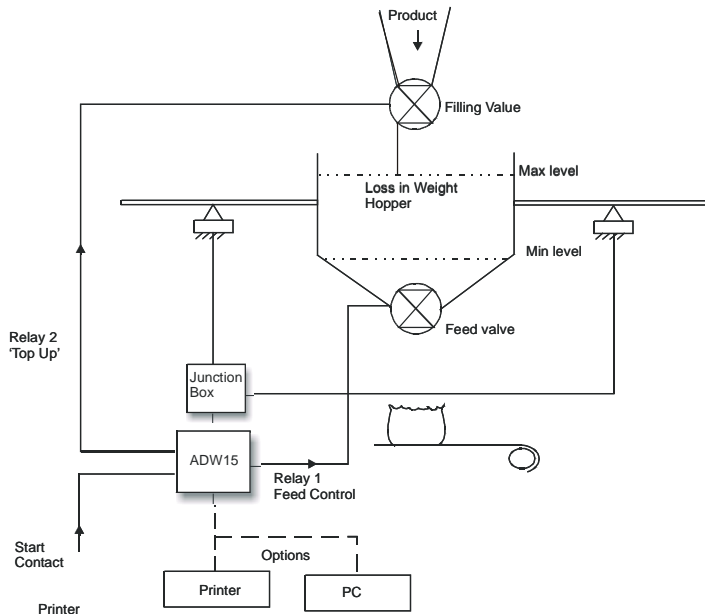

Brief Description

Hardware is based on the ADW15, and controls the filling of containers from a hopper by controlling the action of the valves. The valves operating from preset values programmed into the ADW-LW.

Operational Outline

There are two outputs, one controlling the filling valve to allow the hopper to be filled or topped up and one controlling the hopper discharge valve.

On pressing the start contact, the hopper is checked to confirm that sufficient material is available to reach the setpoint value (SP), and that the gross weight is greater than the hopper low level (HLL).

If this is correct an autotare occurs and the feed valve opens until the set point is reached (SP-IF). On reaching the setpoint, and after the settle time (St) has elapsed, a print function can be initiated showing the result of the fill, together with the bag/container number (Ln).

If, however, on receiving a start input insufficient material is available or the hopper level is less than that of the hopper low level (HLL), the hopper fill valve will be opened by relay 2 until the hopper high level (HHL) is reached. On reaching the level, a timer is started for a period set in (T1); after this period the discharge is started.

If a further start signal is received during the refilling of the hopper, and when sufficient material is available then discharge can be initiated.

A start signal is ignored if the settle time has not elapsed.

The analogue output value is taken from the hopper gross value.

Calibration

The calibration sequence is described in the ADW15 manual

Table 1

net	Live net value
gros	Live gross value of hopper weight
SP	Discharge setpoint value
IF	Discharge In Flight value
PASS	Password (as for ADW15)
HHL	Hopper high level value
HLL	Hopper low level value
tl	Time delay from hopper refill complete to starting discharge (set in seconds)
St	Hopper settle time (set in seconds)
CALL	Low calibration value (as for ADW15)
CALH	High calibration value (as for ADW15)
At	Autotare value
dA	Display averaging and select default display for gross or net (0-7 net), (8-15 gross)
OPL	Output low value (as for ADW15)
OPH	Output high value (as for ADW15)
dp	Decimal point position
Cp	Communications for printer number
Sdst/Lab	Station device/label
Ln	Log number
rS	Resolution value
Inp	Input live value
	(dp - Inp inclusive refer to ADW15 manual)

NOTE: Default display can be selected from the gross or net incremental weight flowing into the receiving containers

ADW Communications Commands/Mnemonics

(CP1 MANTRABUS Fast Format)

The Command Format is similar to that used on the ADW15

Table 2

COMMAND No.

DEC	HEX	Description	
1	1	REQUEST ALL VARIABLES (AS ADW15)	
2	2	REQUEST DISPLAY DATA (AS ADW15)	
3	3	INHIBITED. RETURNS A 'NAK'	(NEt)
4	4	INHIBITED. RETURNS A 'NAK'	(grOS)
5	5	UPDATE SET POINT	(SP)
6	6	UPDATE IN FLIGHT	(IF)
7	7	UPDATE HOPPER HIGH LEVEL	(HHL)
8	8	UPDATE HOPPER LOW LEVEL	(HLL)
9	9	UPDATE TIMER	(t1)
10	A	UPDATE OUTPUT SETTLE TIME	(St)
11	B	INHIBITED. RETURNS A 'NAK'	
12	C	INHIBITED. RETURNS A 'NAK'	
13	D	INHIBITED. RETURNS A 'NAK'	(CALL)
14	E	INHIBITED. RETURNS A 'NAK'	(CALH)
15	F	UPDATE AUTOTARE	(At)
16	10	UPDATE DISPLAY AVERAGES	(DA)
17	11	UPDATE OUTPUT LOW	(OPL)
18	12	UPDATE OUTPUT HIGH	(OPH)
19	13	UPDATE DECIMAL POINT	(DP)
20	14	INHIBITED. RETURNS A 'NAK'	(CP) (LAB/SDSt)
21	15	INHIBITED. RETURNS A 'NAK'	(Ln)
22	16	UPDATE LOG NUMBER	(rS)
23	17	UPDATE DISPLAY RESULTION	(AS ADW15)
24	18	E2ROM ENABLE/DISABLE	
25	19	REQUEST START	

Response To Command 1 From ADW

Table 3

BYTE		
1	Station number	(SDSt)
2,3	SELECTED DISPLAY	(NET/GROSS)
4,5	NET	(NEt)
6,7	GROSS	(grOS)
8,9	SET POINT	(SP)
10,11	IN FLIGHT	(IF)
12,13	HOPPER HIGH LEVEL	(HHL)
14,15	HOPPER LOW LEVEL	(HLL)
16,17	TIMER 1	(t1)
18,19	SETTLE TIME	(St)
20,21	A/D COUNTS FOR LOW CALIBRATION POINT	
22,23	A/D COUNTS FOR HIGH CALIBRATION POINT DISPLAY LOW	
24,25	CALIBRATION VALUE	(CALL)
26,27	DISPLAY HIGH CALIBRATION VALUE	(CALH)
28,29	AUTO TARE	(At)
30,31	DISPLAY AVERAGING	(DA)
32,33	OUTPUT LOW	(OPL)
34,35	OUTPUT HIGH	(OPH)
36,37	DECIMAL POINT POSITION	(DP)
38,39	COMMS PROTOCOL	(CP)
40,41	SERIAL DEVICE STATION NUMBER/LABEL	(LAB/SDSt)
42,43	LOG NUMBER	(Ln)
44,45	DISPLAY RESOLUTION	(rS)
46	E2ROM ENABLE/DISABLE	FLAG
47	RELAY STATUS	
48	EXOR CHECKSUM OF THE ABOVE DATA	

Response To Command 2 From ADW

Table 4

BYTE	
1	Station number
2	DISPLAY READING MSB
3	DISPLAY READING MSB
4	EXOR CHECKSUM OF THE ABOVE DATA

CP2 (ASCII Format)

Table 5

Note for Operation see ADW15 Manual

LABELS	Description	
DISP	REQUEST READING DISPLAY	
NT	NET VALUE	(NEt)
GROS	GROSS VALUE	(grOS)
SP	SET POINT	(SP)
IF	IN FLIGHT	(IF)
HHL	HOPPER HIGH LEVEL	(HHL)
HLL	HOPPER LOW LEVEL	(HLL)
TM1	TIMER 1	(t1)
ST	SETTLE TIME	(St)
AT	AUTO TARE	(At)
DA	DISPLAY AVERAGES	(DA)
OPL	OUTPUT LOW	(OPL)
OPH	OUTPUT HIGH	(OPH)
DP	DECIMAL POINT	(DP)
LN	LOG NUMBER	(Ln)
RS	DISPLAY RESOLUTION	(rS)
DROM	DISABLE E2ROM (DROM = 256)	
ERRD	ENABLE E2ROM AND READ FROM IT	
ERWD	ENABLE E2ROM AND WRITE TO IT	
RLYS	OUTPUT RELAY STATUS (0 = BOTH OFF, 1 = RELAY 1 ON, 2 = RELAY 2 ON, 3 = BOTH RELAYS ON)	
RES	START	

Figure 2 ADW-LW Loss in Weight Procedure

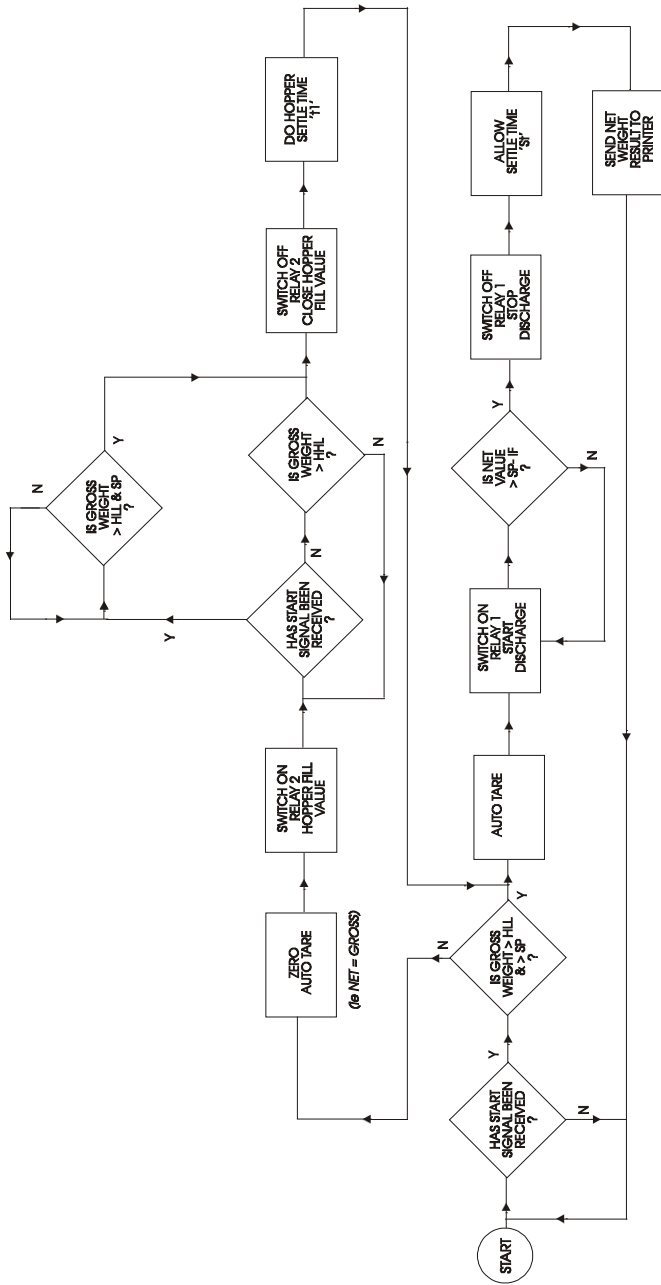

In the interests of continued product development, Mantracourt Electronics Limited reserves the right to alter product specifications without prior notice.